



eMaxion™ Acuator Data Sheet

eMaxion™ Actuators

Introducing eMaxion™, a stepper motor actuator designed for the requirements of the biotech industry. This actuator is engineered to enable unparalleled precision of position control and increased efficiency by eliminating compressed air utility.

eMaxion™ is significantly more compact than comparable offerings of pneumatic and electrical actuators and addresses a complete range of valve automation requirements from discrete on/off to fine modulating control.

Its industry standard motor and electrical connector simplifies implementation.

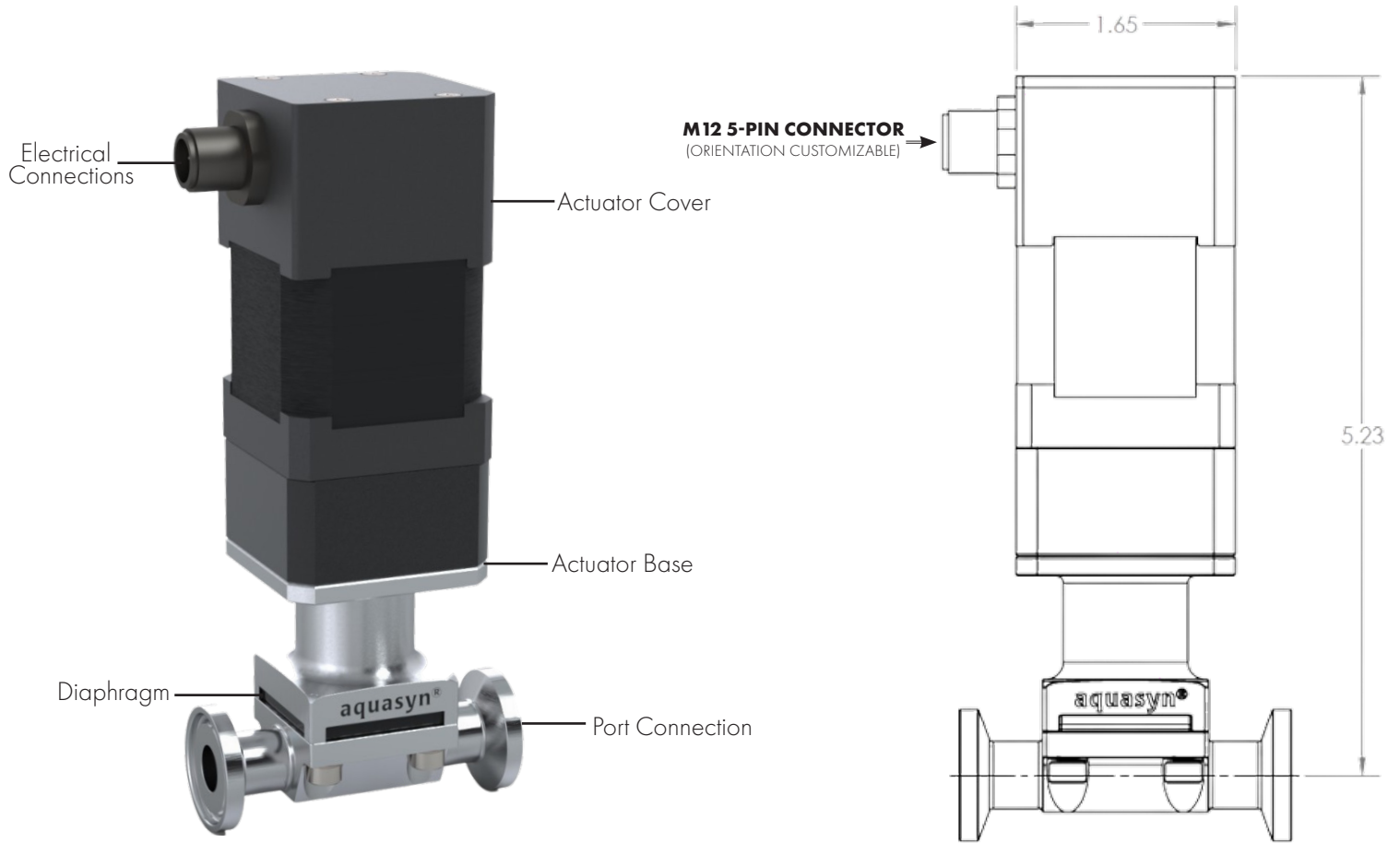

Technical Data

Performance Data	
Operating Pressure	60 psi
Stroke Travel Time	0.5 seconds
Mass	706 grams
Available Sizing	½ in
End Connections	Refer to Aquasyn catalog
Electrical Specifications	
Control	Bipolar stepper
Electrical Connector	M 12 5-pin (non-encoder)
Stroke Resolution	704 steps (can be microstepped)
Environmental Ratings	
Ingress Protection	IP 65
Ambient Temperature Range	-10°C to 50°C (14°F to 122°F)

Key Benefits

- Minimal Space Requirement
- No Compressed Air
- Industry Standard Stepper
- On/Off to Fine Modulation
- Eliminates Water Hammer
- Interchangeable Bonnet

